

- A) Forare il cartongesso a seconda delle dimensioni del prodotto.
A) Cut the plasterboard according to the size of the product.

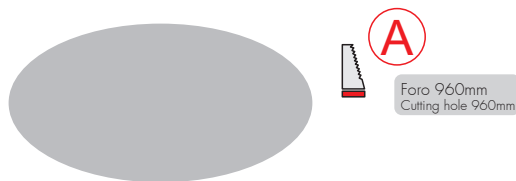

- B) Rimuovere le staffe ed inserire la controcassa nel cartongesso.
B) Remove the stirrups and insert the outer casing in the plasterboard.

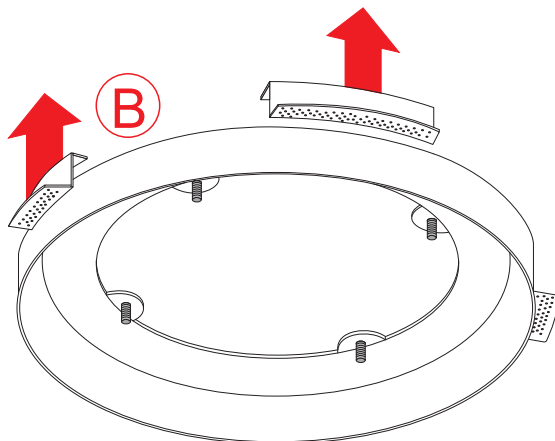

- C) Inserire le staffe nella controcassa fissandole tramite i galletti.
C) Insert the stirrups in the outer casing fixing them through the wing nuts.

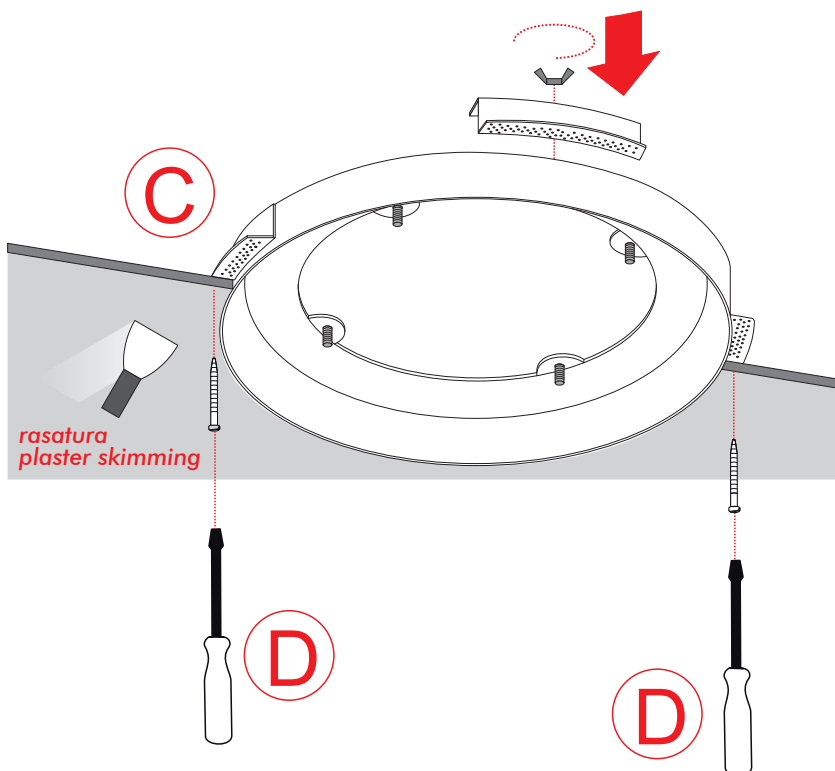

- D) Fissare le staffe al cartongesso tramite le apposite viti.
D) Fix the stirrups to the plasterboards using the adequate screws.

PRODOTTO / PRODUCT

Controcassa Bellai Home
Outer casing Bellai Home

MONTAGGIO / MOUNTING

Incasso/Recessed

CODICI / CODES

4027F

n°INSTALLATORI / INSTALLERS n°



STRUMENTI / INSTRUMENTS

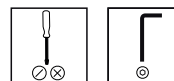

TEMPO / TIME



CERTIFICAZIONI / CERTIFICATIONS



ATTENZIONE / CAUTION



Togliere la rete di alimentazione prima dell'installazione, sostituzione della lampada e comunque prima di ogni operazione di manutenzione.

Always turn off the power supply before installing, the replacement of the light bulb and to any maintenance intervention.



La sicurezza dell'apparecchio è garantita solo con l'uso appropriato delle seguenti istruzioni; pertanto è necessario consultarle e conservarle.

The safety of this product is guaranteed only if correctly used, according to this instruction sheet, which must be read first

F) Inserire il prodotto nella controcassa e stringere i galletti.
F) Insert the product in the outer casing and tight the wing nuts.

G) Effettuare il collegamento elettrico.
G) Make the electrical connection.



3027FOF(DM)(TF) not included

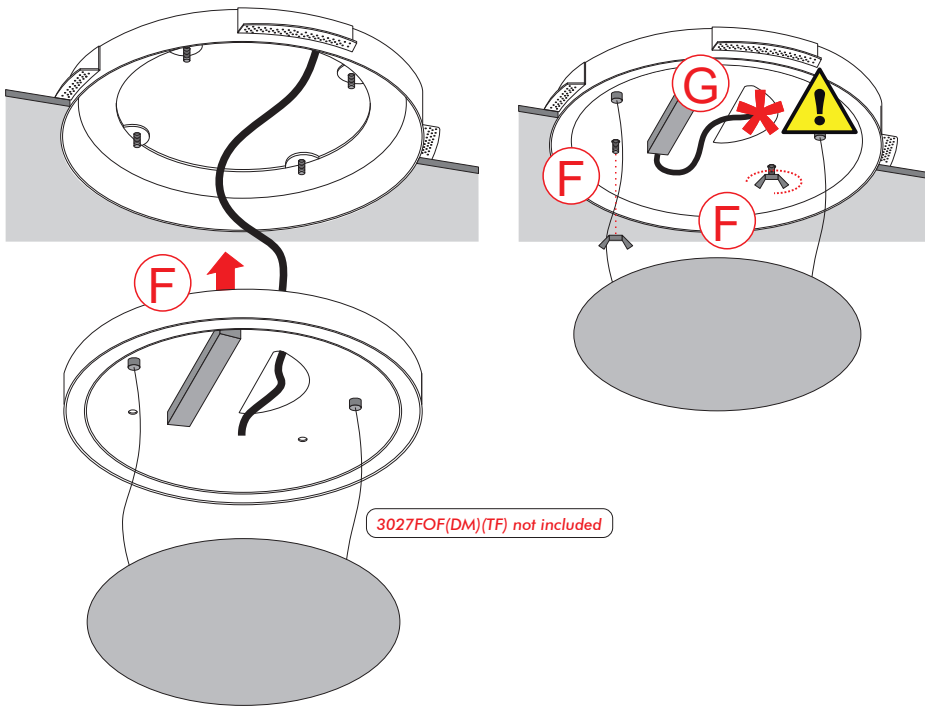

H) Chiudere il fondo con la cover magnetica.
H) Close the bottom with the magnetic cover.

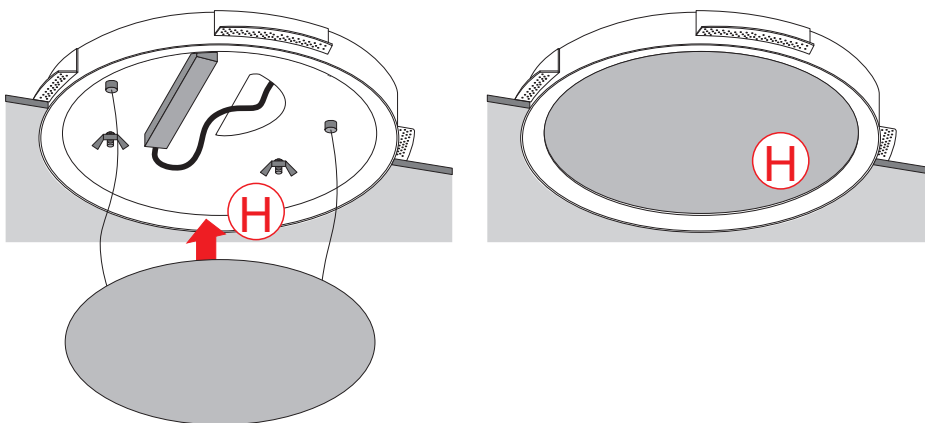

PRODOTTO / PRODUCT

Controcassa Bellai Home
Outer casing Bellai Home

MONTAGGIO / MOUNTING

Incasso/Recessed

CODICI / CODES

9027F compatibile con 3027F
9027F suitable for 3027F

n°INSTALLATORI / INSTALLERS n°



STRUMENTI / INSTRUMENTMENTS

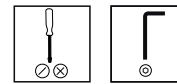

TEMPO / TIME



CERTIFICAZIONI / CERTIFICATIONS



ATTENZIONE / CAUTION



Togliere la rete di alimentazione prima dell'installazione, sostituzione della lampada e comunque prima di ogni operazione di manutenzione.

Always turn off the power supply before installing, the replacement of the light bulb and to any maintenance intervention.



La sicurezza dell'apparecchio è garantita solo con l'uso appropriato delle seguenti istruzioni; pertanto è necessario consultarle e conservarle.

The safety of this product is guaranteed only if correctly used, according to this instruction sheet, which must be read first

COLLEGAMENTO ELETTRICO * ELECTRICAL CONNECTION



Attenzione! Togliere la rete di alimentazione prima dell'installazione, sostituzione della lampada e comunque prima di ogni operazione di manutenzione.

Caution! Always turn off power supply before install, replacing of the light bulb and prior to any maintenance interventions.

ON/OFF

Versione ONOFF
ONOFF Version



DM

Versione dimmerabile - Collegamento con pulsante
Dimmable Version - Touch-DIM wiring

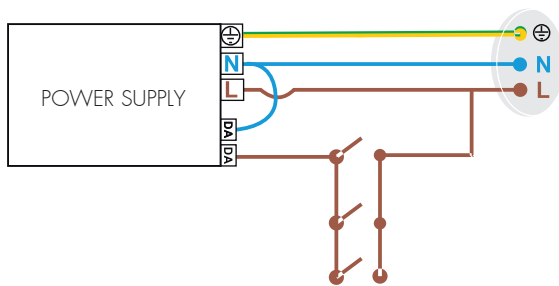

Touch-DIM

Sincronizzazione di più apparecchi:
premere il pulsante per 40 secondi

Synchronizing multiple devices:
Press the button for 40 seconds

Mehrere Geräte synchronisieren:
Taste 40 Sekunden lang gedrückt halten.

DM

Versione dimmerabile - Collegamento con sistema di gestione
Dimmable Version - Management System wiring

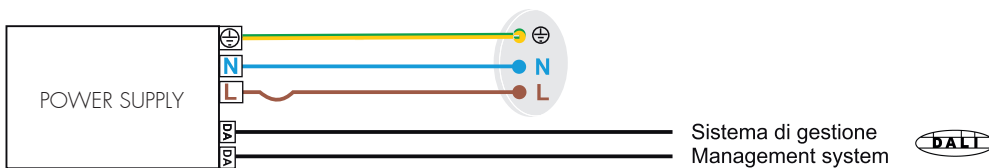

TF

Versione TAGLIO DI FASE

