

- A) Forare il cartongesso a seconda delle dimensioni del prodotto.
A) Cut the plasterboard according to the size of the product.

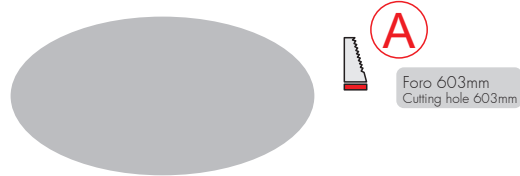

- B) Rimuovere le staffe ed inserire la controcassa nel cartongesso.
B) Remove the stirrups and insert the outer casing in the plasterboard.

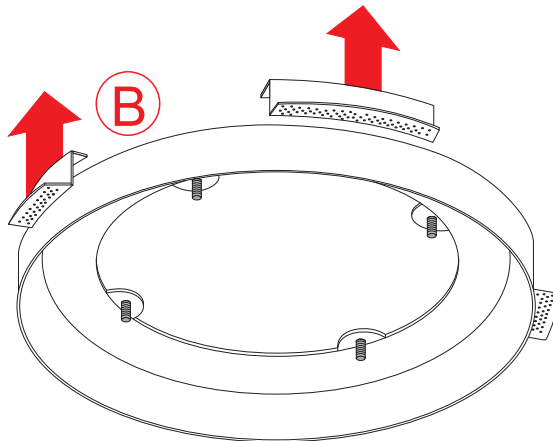

- C) Inserire le staffe nella controcassa fissandole tramite i galletti.
C) Insert the stirrups in the outer casing fixing them through the wing nuts.

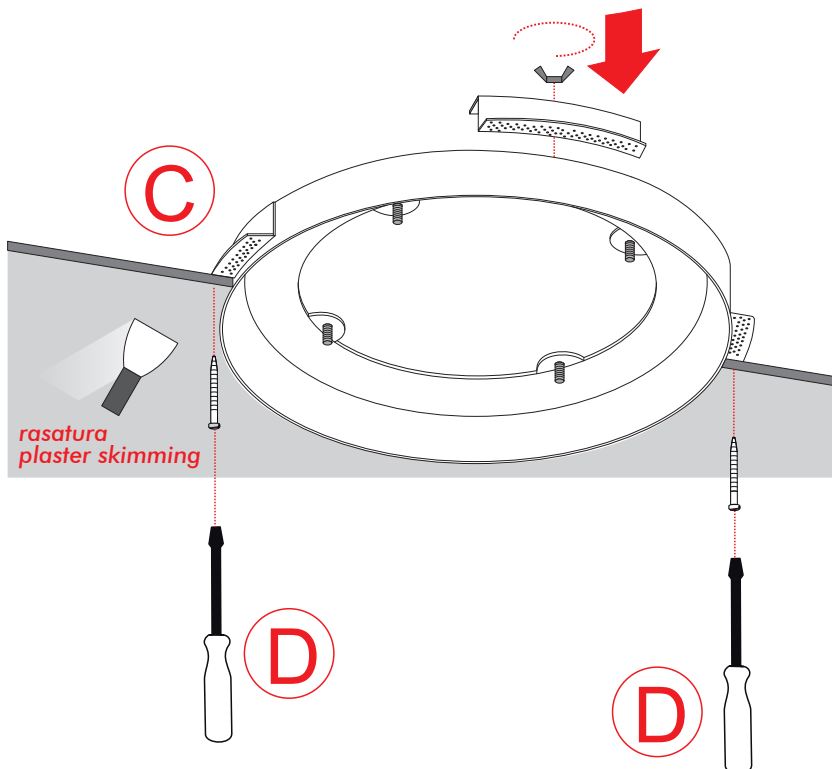

- D) Fissare le staffe al cartongesso tramite le apposite viti.
D) Fix the stirrups to the plasterboards using the adequate screws.

PRODOTTO / PRODUCT

Controcassa Bellai Home
Outer casing Bellai Home

MONTAGGIO / MOUNTING

Incasso/Recessed

CODICI / CODES

4027E

n°INSTALLATORI / INSTALLERS n°



STRUMENTI / INSTRUMENTS

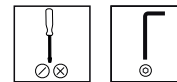

TEMPO / TIME



CERTIFICAZIONI / CERTIFICATIONS



ATTENZIONE / CAUTION



Togliere la rete di alimentazione prima dell'installazione, sostituzione della lampada e comunque prima di ogni operazione di manutenzione.

Always turn off the power supply before installing, the replacement of the light bulb and to any maintenance intervention.



La sicurezza dell'apparecchio è garantita solo con l'uso appropriato delle seguenti istruzioni; pertanto è necessario consultarle e conservarle.

The safety of this product is guaranteed only if correctly used, according to this instruction sheet, which must be read first

F) Inserire il prodotto nella controcassa e stringere i galletti.
F) Insert the product in the outer casing and tight the wing nuts.

G) Effettuare il collegamento elettrico. * ⚠
G) Make the electrical connection.

3027EOF(DM)(TF) not included

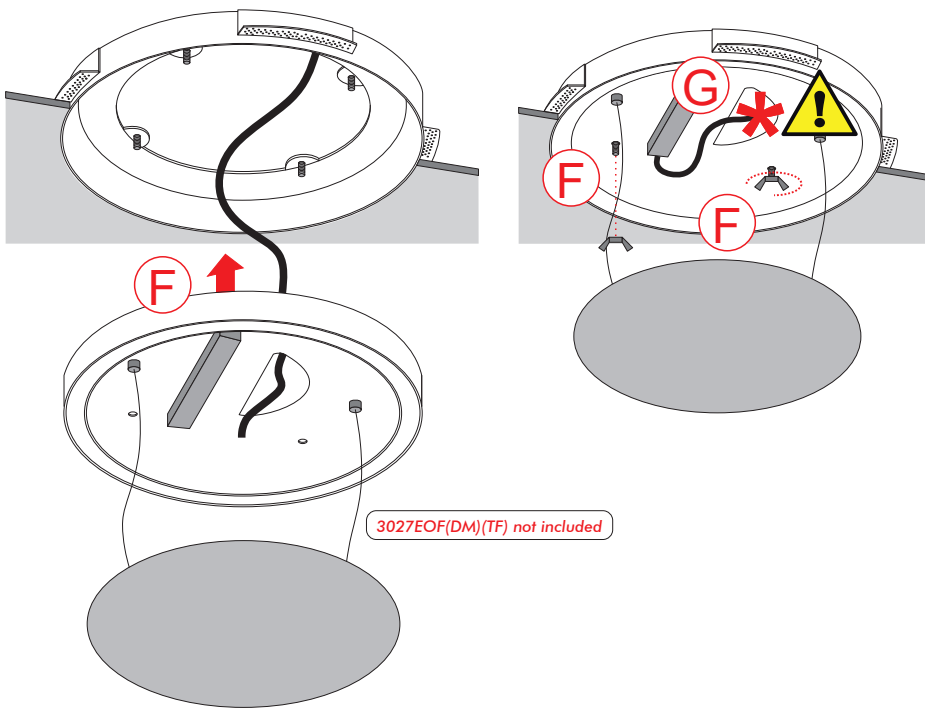

H) Chiudere il fondo con la cover magnetica.
H) Close the bottom with the magnetic cover.

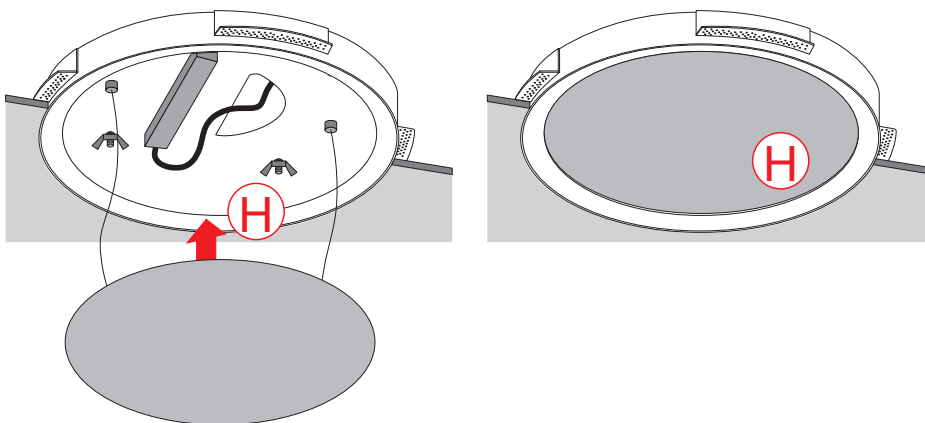

PRODOTTO / PRODUCT

Controcassa Bellai Home
Outer casing Bellai Home

MONTAGGIO / MOUNTING

Incasso/Recessed

CODICI / CODES

9027E compatibile con 3027E
9027E suitable for 3027E

n°INSTALLATORI / INSTALLERS n°



STRUMENTI / INSTRUMENTS

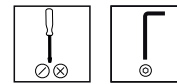

TEMPO / TIME



CERTIFICAZIONI / CERTIFICATIONS



ATTENZIONE / CAUTION



Togliere la rete di alimentazione prima dell'installazione, sostituzione della lampada e comunque prima di ogni operazione di manutenzione.

Always turn off the power supply before installing, the replacement of the light bulb and to any maintenance intervention.



La sicurezza dell'apparecchio è garantita solo con l'uso appropriato delle seguenti istruzioni; pertanto è necessario consultarle e conservarle.

The safety of this product is guaranteed only if correctly used, according to this instruction sheet, which must be read first

COLLEGAMENTO ELETTRICO * ELECTRICAL CONNECTION



Attenzione! Togliere la rete di alimentazione prima dell'installazione, sostituzione della lampada e comunque prima di ogni operazione di manutenzione.

Caution! Always turn off power supply before install, replacing of the light bulb and prior to any maintenance interventions.

ON/OFF

Versione ONOFF
ONOFF Version



DM

Versione dimmerabile - Collegamento con pulsante
Dimmable Version - Touch-DIM wiring

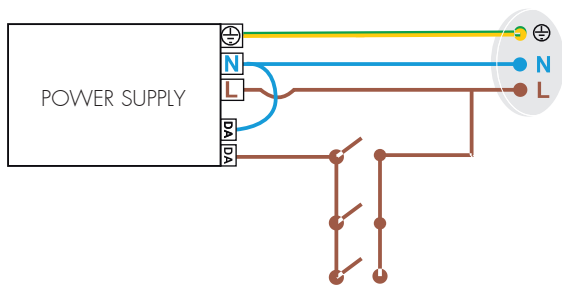

Touch-DIM

DM

Versione dimmerabile - Collegamento con sistema di gestione
Dimmable Version - Management System wiring

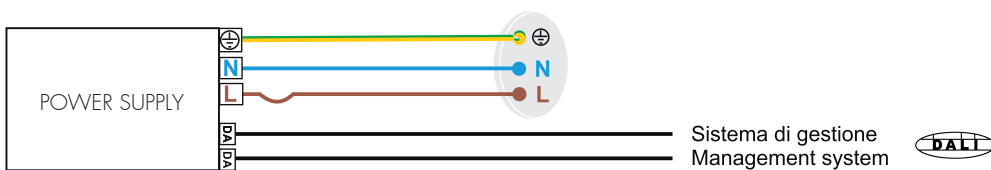

TF

Versione TAGLIO DI FASE

