

ISTRUZIONI DI MONTAGGIO

ASSEMBLY INSTRUCTIONS

- 1) Fissare i regolatori millimetrici a plafone
- 1) Fix the millimetric adjustment system for ceiling

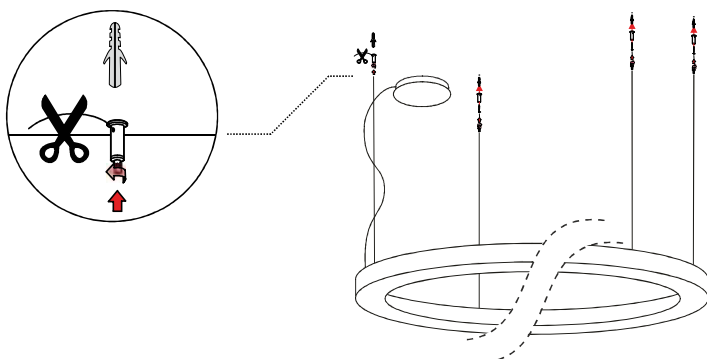

- 2) Aprire la cover
- 2) Open the cover

- 3) Fissare il rosone
- 3) Fix the ceiling rose

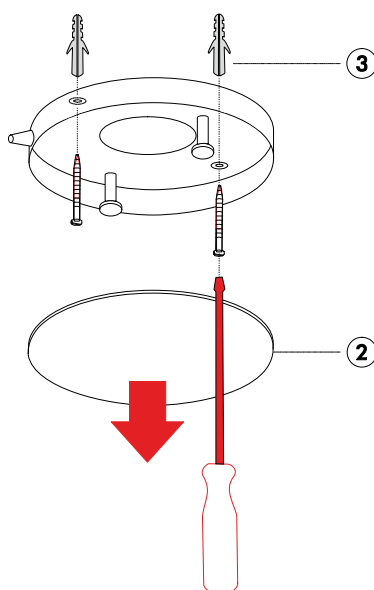

- 4) Effettuare il collegamento elettrico
- 4) Make the electrical connection



- 5) Richiudere la cover
- 5) Close the cover

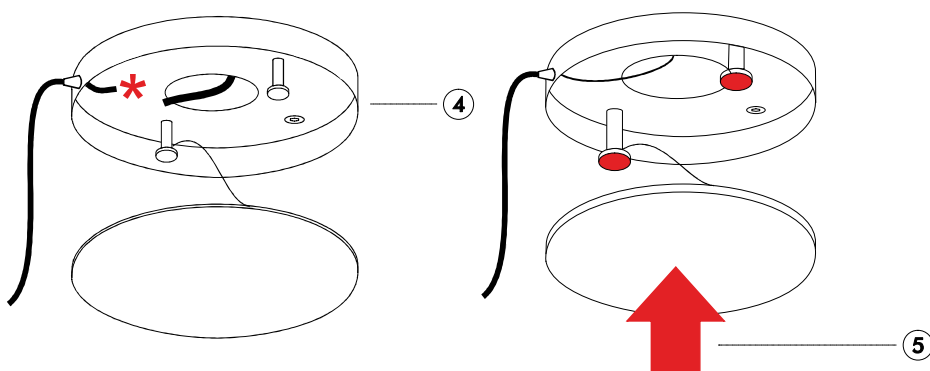

PRODOTTO / PRODUCT

BELLAI

MONTAGGIO / MOUNTING

Sospensione / Suspension

CODICI / CODES

1025DOF - 1025DDM - 1025DOF **EM**

n°INSTALLATORI / INSTALLERS n°



STRUMENTI / INSTRUMENTS



TEMPO / TIME



CERTIFICAZIONI / CERTIFICATIONS



ATTENZIONE / CAUTION



Togliere la rete di alimentazione prima dell'installazione, sostituzione della lampada e comunque prima di ogni operazione di manutenzione.

Always turn off power supply before install, replacing of the light bulb and prior to any maintenance interventions.



La sicurezza dell'apparecchio è garantita solo con l'uso appropriato delle seguenti istruzioni; pertanto è necessario consultarle e conservarle.

The safety of this product is guaranteed only if correctly used, according to this instruction sheet, which must be read first

COLLEGAMENTO ELETTRICO ELECTRICAL CONNECTION



Attenzione! Togliere la rete di alimentazione prima dell'installazione, sostituzione della lampada e comunque prima di ogni operazione di manutenzione.

Caution! Always turn off power supply before install, replacing of the light bulb and prior to any maintenance interventions.

ON/OFF

Versione ONOFF
ONOFF Version

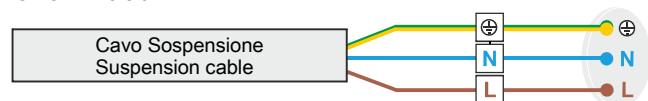

ON/OFF EM

Versione ONOFF + Emergenza
ONOFF + Emergency Version

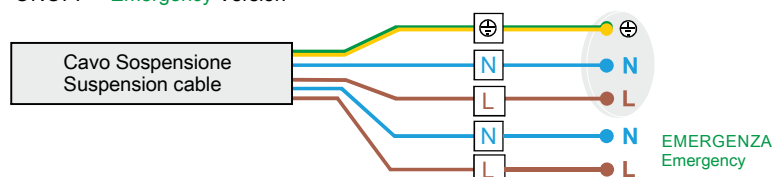

DM

Versione dimmerabile - Collegamento con pulsante
Dimmable Version - Touch-DIM wiring

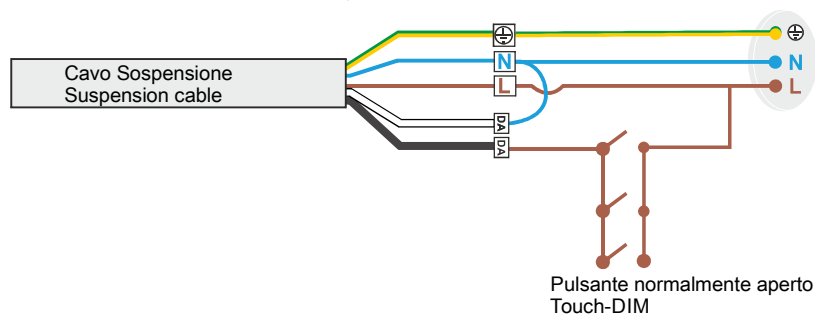

DM

Versione dimmerabile - Collegamento con sistema di gestione DALI
Dimmable Version DALI - Management system wiring DALI

