

ISTRUZIONI DI MONTAGGIO ASSEMBLY INSTRUCTIONS

A) Avvitare i perni sul corpo lampada
A) Screw the pins onto the lamp body

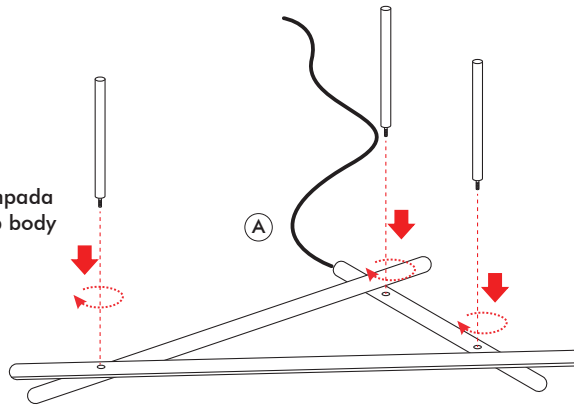

B) Fissare le boccole a soffitto
B) Fixing ceiling bushings

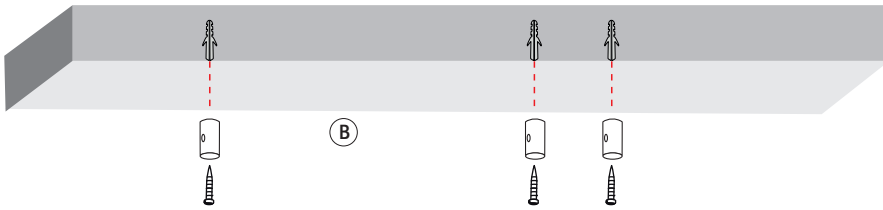

C) Inserire perni nelle boccole e stringere con i grani
C) Insert pins into the bushings and tighten with grub screws

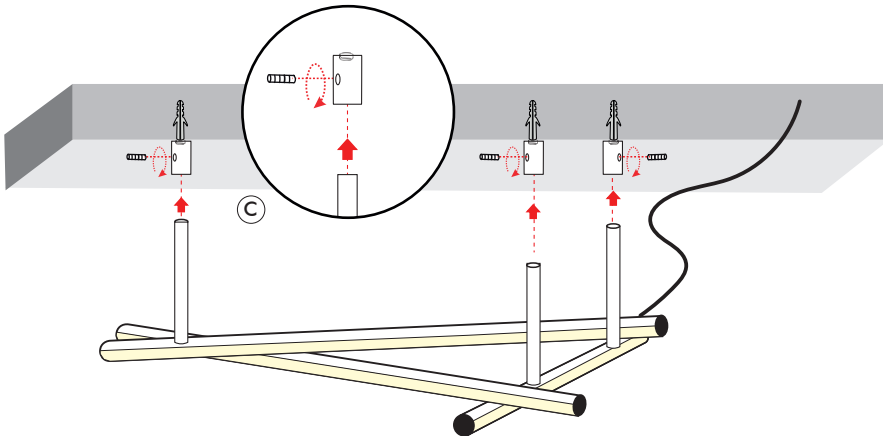

D) Fissare il rosone a soffitto ed effettuare il collegamento elettrico
D) Fix the ceiling rose and make the electrical connection

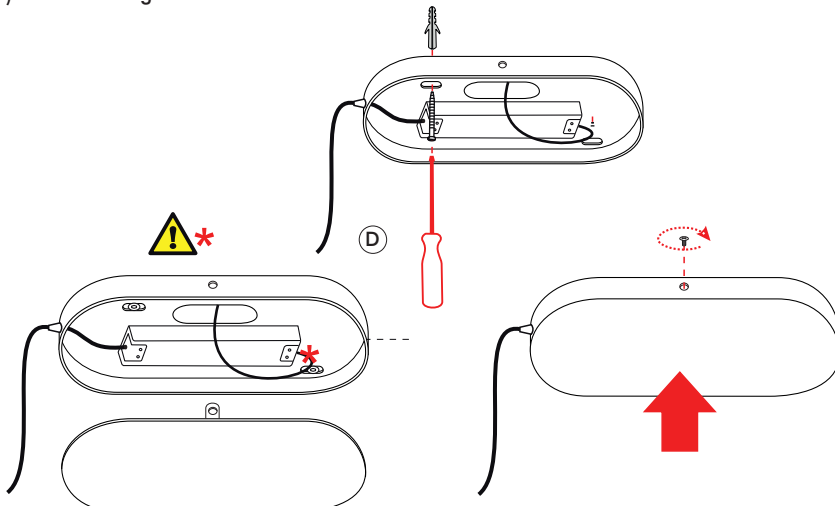

ISTRUZIONI DI MONTAGGIO Rev.A ASSEMBLY INSTRUCTIONS

PRODOTTO / PRODUCT

Overlap Decò

MONTAGGIO / MOUNTING

Sospensione / Suspension

CODICI / CODES

3015QTF - 3015QDM - 3015QSD

n°INSTALLATORI / INSTALLERS n°



STRUMENTI / INSTRUMENTS



TEMPO / TIME



CERTIFICAZIONI / CERTIFICATIONS



ATTENZIONE / CAUTION



Togliere la rete di alimentazione prima dell'installazione, sostituzione della lampada e comunque prima di ogni operazione di manutenzione.

Always turn off power supply before install, replacing of the light bulb and prior to any maintenance interventions.



La sicurezza dell'apparecchio è garantita solo con l'uso appropriato delle seguenti istruzioni; pertanto è necessario consultarle e conservarle.

The safety of this product is guaranteed only if correctly used, according to this instruction sheet, which must be read first

COLLEGAMENTO ELETTRICO * ELECTRICAL CONNECTION



Attenzione! Togliere la rete di alimentazione prima dell'installazione, sostituzione della lampada e comunque prima di ogni operazione di manutenzione.

Caution! Always turn off power supply before install, replacing of the light bulb and prior to any maintenance interventions.

OF Versione ONOFF
ONOFF Version



DM Versione dimmerabile - Collegamento con pulsante
Dimmable Version - Touch-DIM wiring

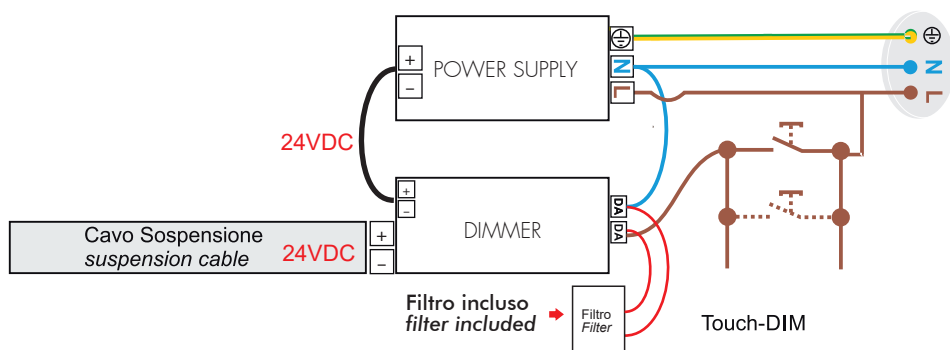

DM Versione dimmerabile - Collegamento con sistema di gestione
Dimmable Version - Management System wiring

